

CLAMPS SHOWN ACTUAL SIZE

# AC101

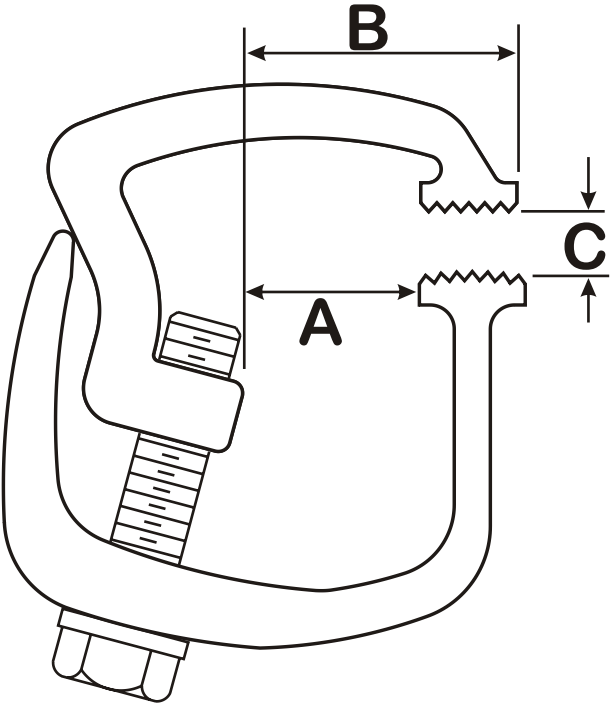

Clamp Width 1-1/4"

- A - 1"
- B - 1-1/2"
- C - 0 to 7/8"

# AC102

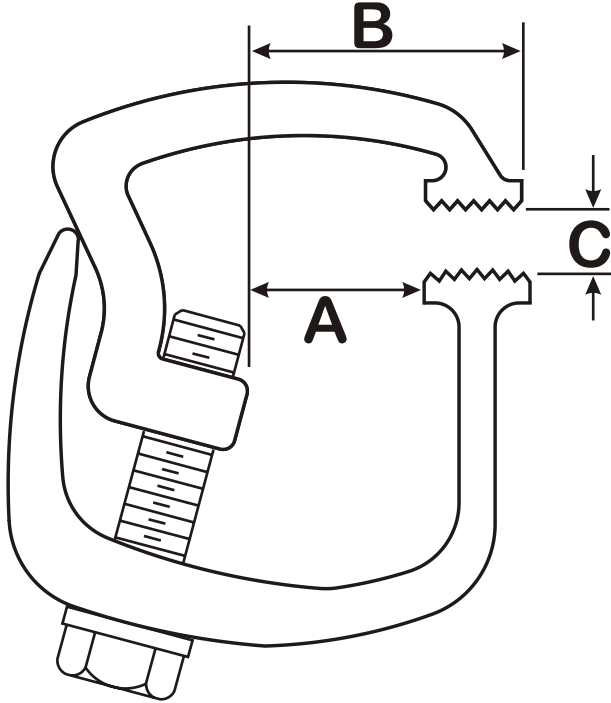

Clamp Width 1"

- A - 1"
- B - 1-1/2"
- C - 0 to 7/8"

CLAMPS SHOWN ACTUAL SIZE

# AC103

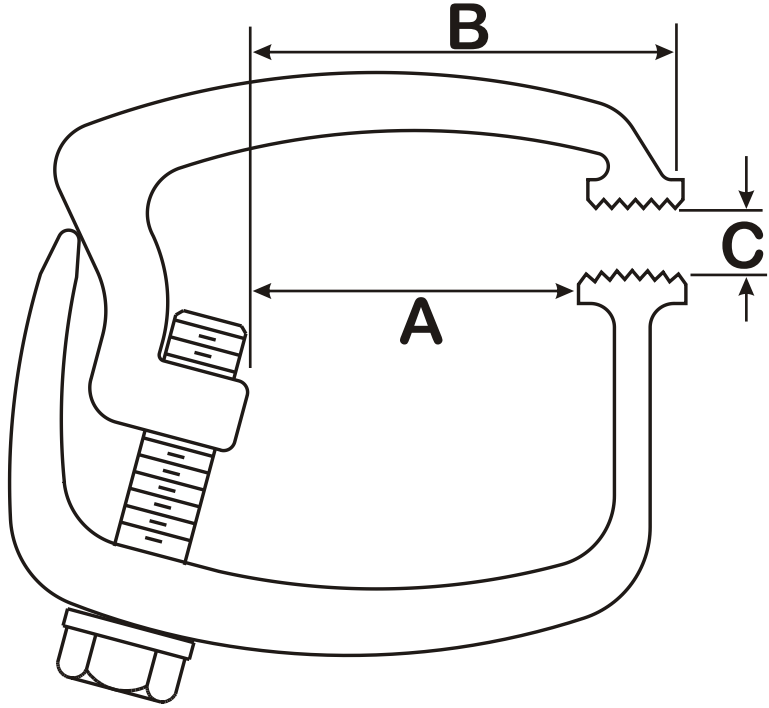

A - 1-3/4"  
B - 2-1/4"  
C - 0 to 7/8"

# AC104

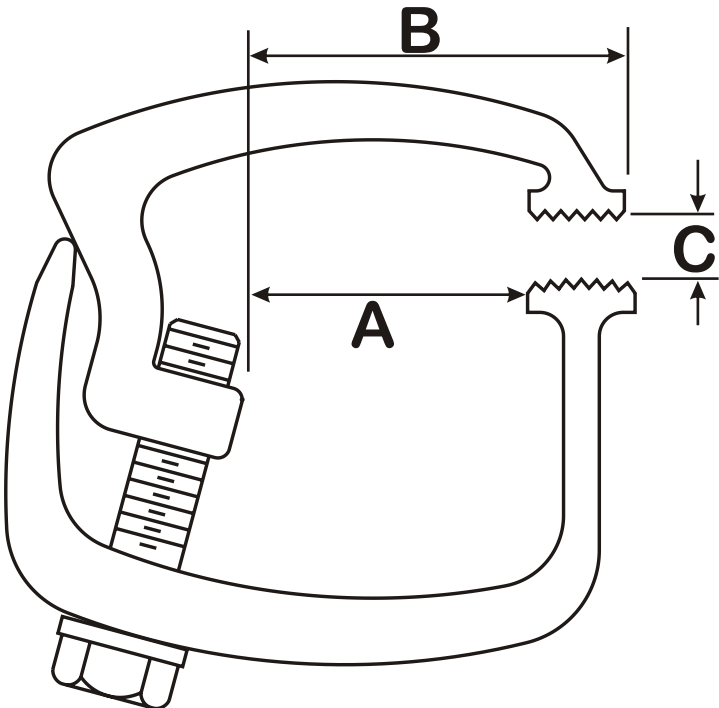

A - 1-1/2"  
B - 2"  
C - 0 to 7/8"

CLAMPS SHOWN ACTUAL SIZE

# AC105

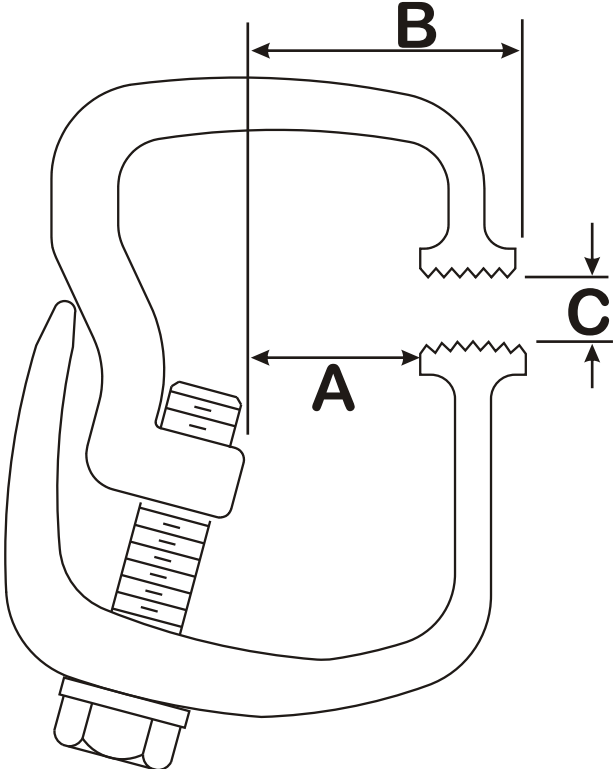

- A - 1"
- B - 1-1/2"
- C - 0 to 7/8"

# AC106

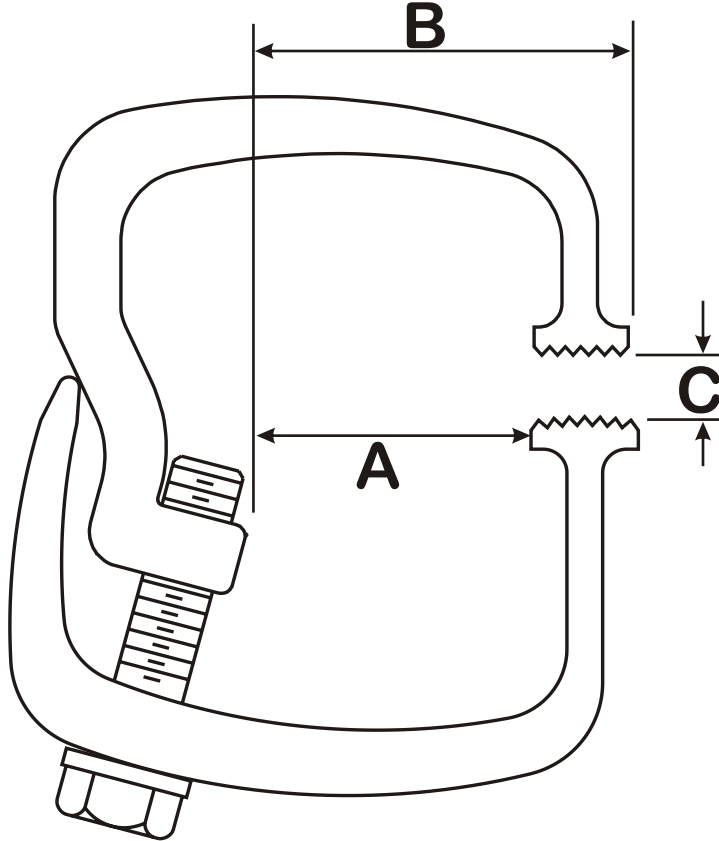

- A - 1-1/2"
- B - 2"
- C - 0 to 7/8"

CLAMPS SHOWN ACTUAL SIZE

**AC1031**

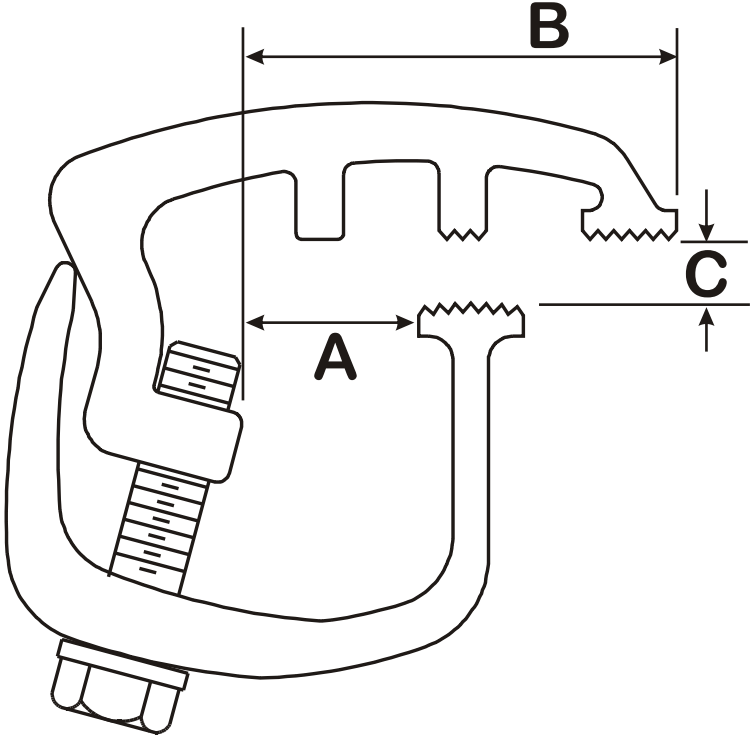

- A - 1"**
- B - 2-1/4"**
- C - 0 to 7/8"**

**AC1081**  
**AC108**

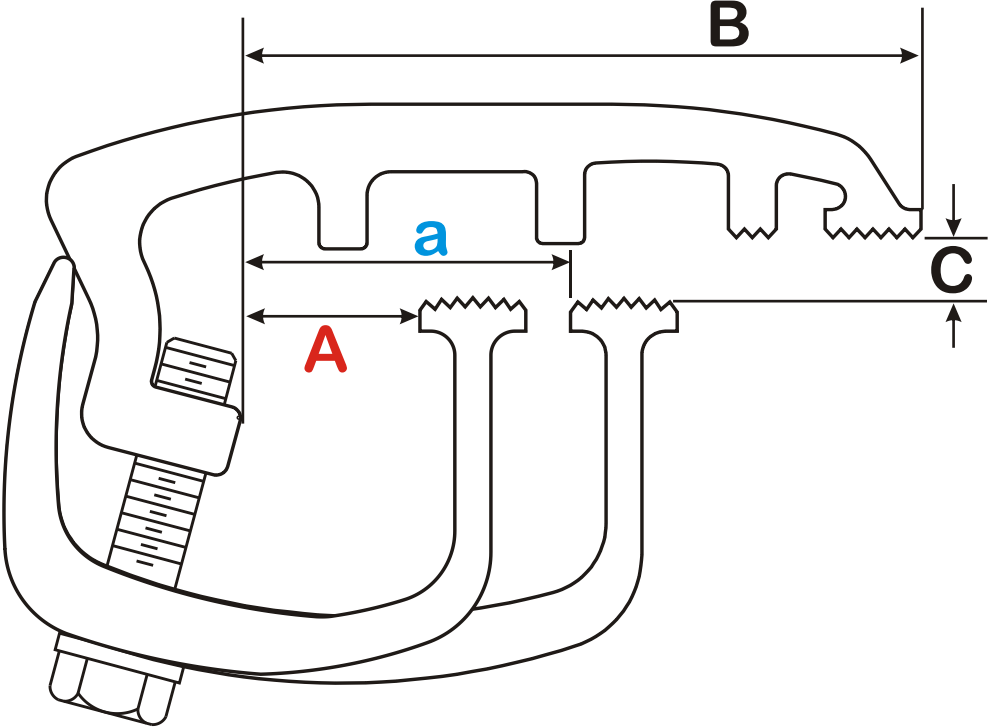

- AC1081** **A - 1"**
- B - 3-1/4"**
- C - 0 to 7/8"**
- AC108** **a - 1-3/4"**
- B - 3-1/4"**
- C - 0 to 7/8"**

CLAMPS SHOWN ACTUAL SIZE

AC109US  
AC109UM  
AC109UL

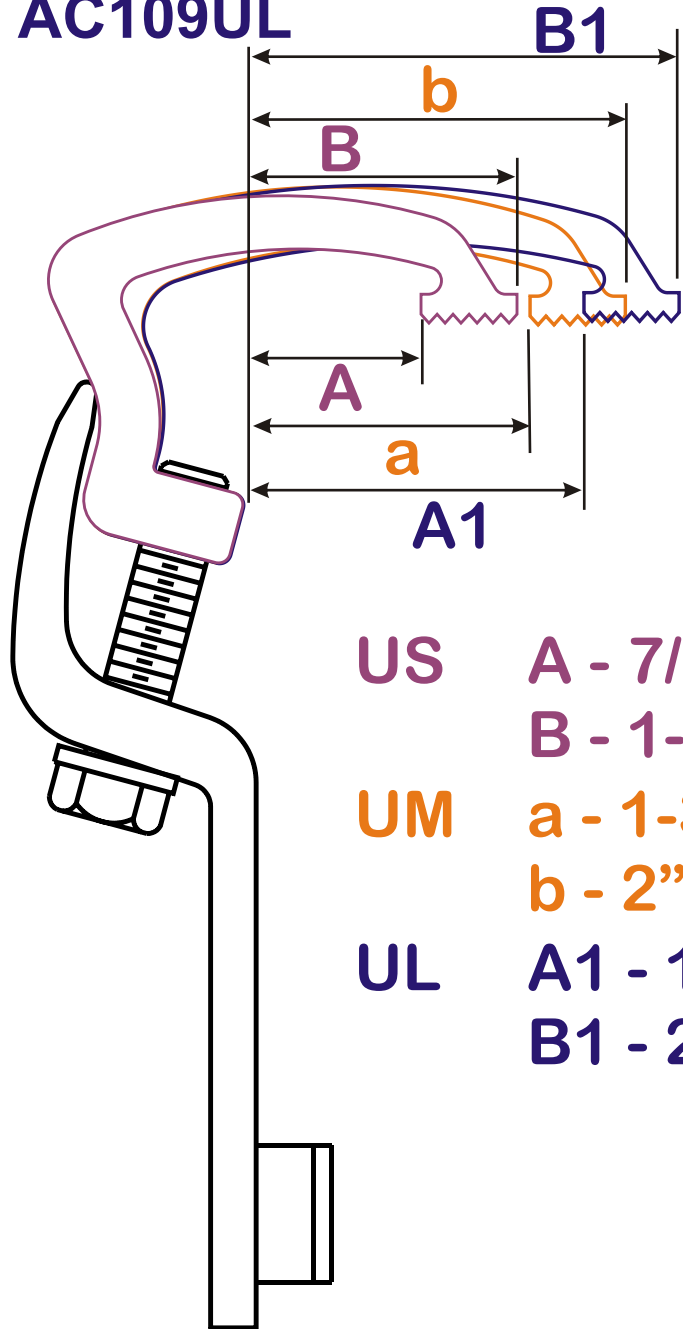

US A - 7/8"  
B - 1-1/2"  
UM a - 1-3/8"  
b - 2"  
UL A1 - 1-5/8"  
B1 - 2-1/8"

**Ford  
FlairSide  
Clamps  
1996 & Prior**

AC109USL  
AC109ULL

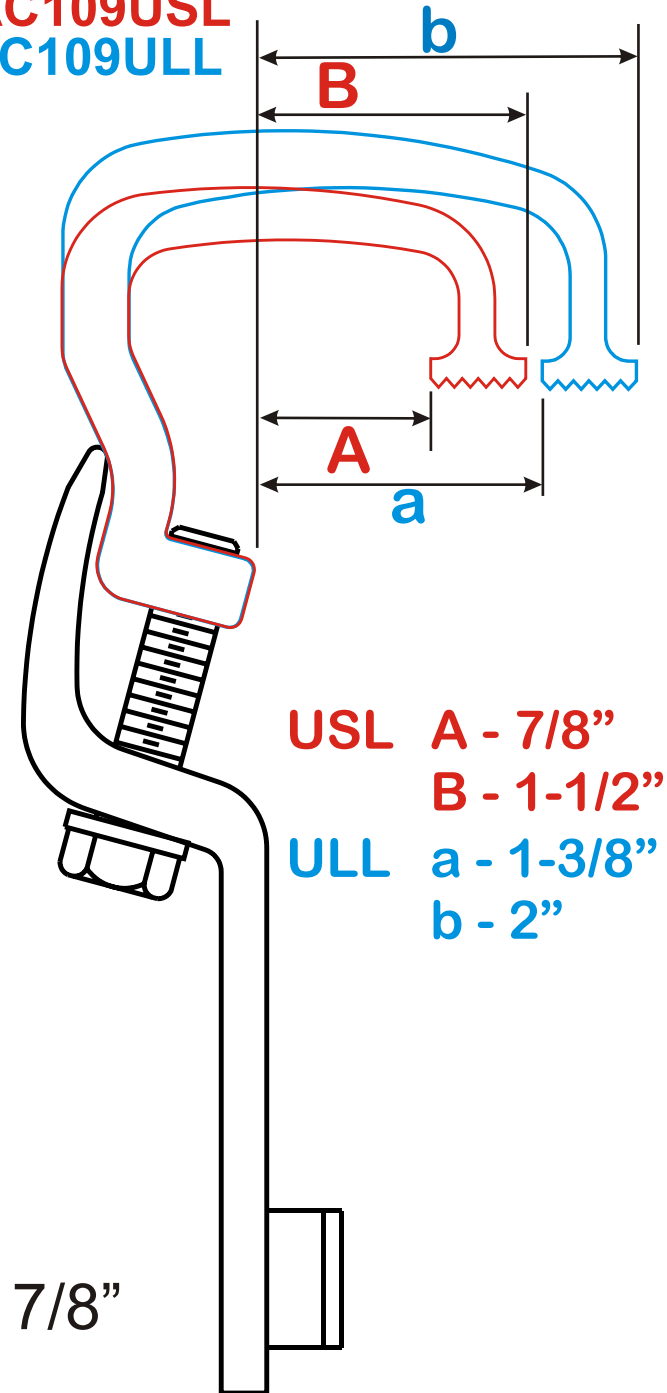

USL A - 7/8"  
B - 1-1/2"  
ULL a - 1-3/8"  
b - 2"

Clamping Range: 7/8"

CLAMPS SHOWN ACTUAL SIZE

AC109US  
AC109UM  
AC109UL

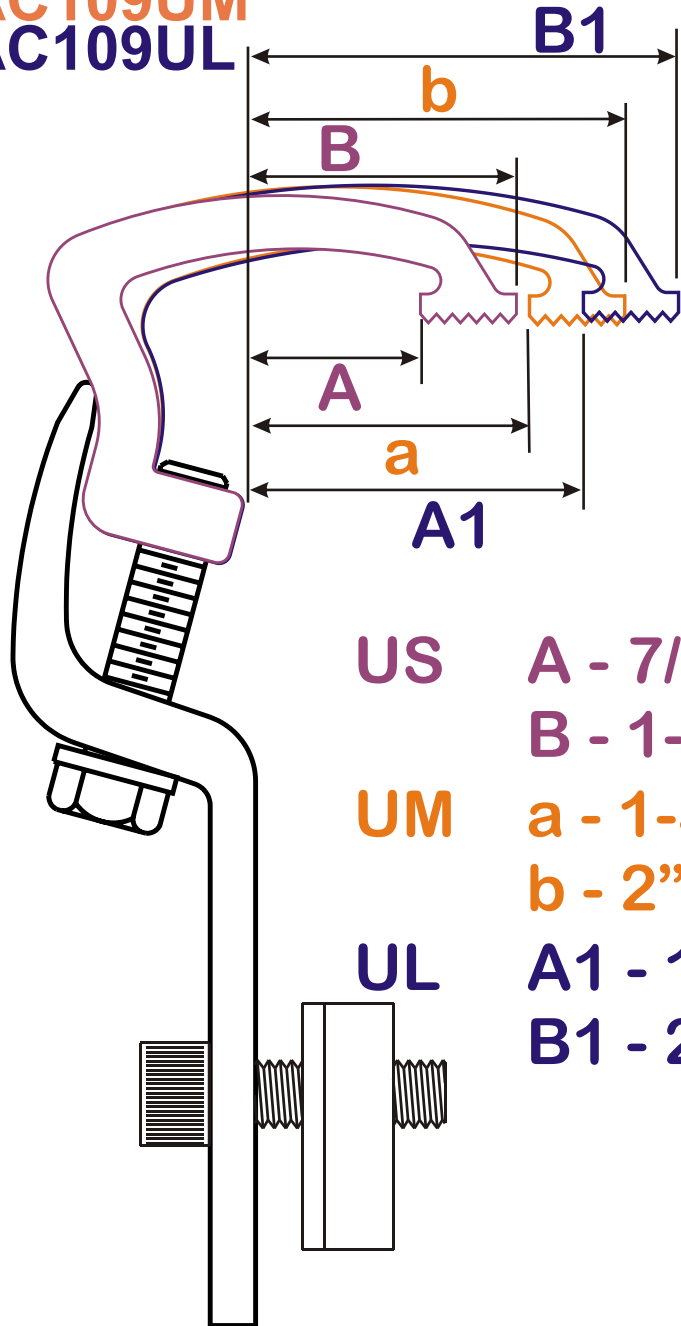

US A - 7/8"  
B - 1-1/2"  
UM a - 1-3/8"  
b - 2"  
UL A1 - 1-5/8"  
B1 - 2-1/8"

**Nissan  
Frontier  
Clamps**

AC109USL  
AC109ULL

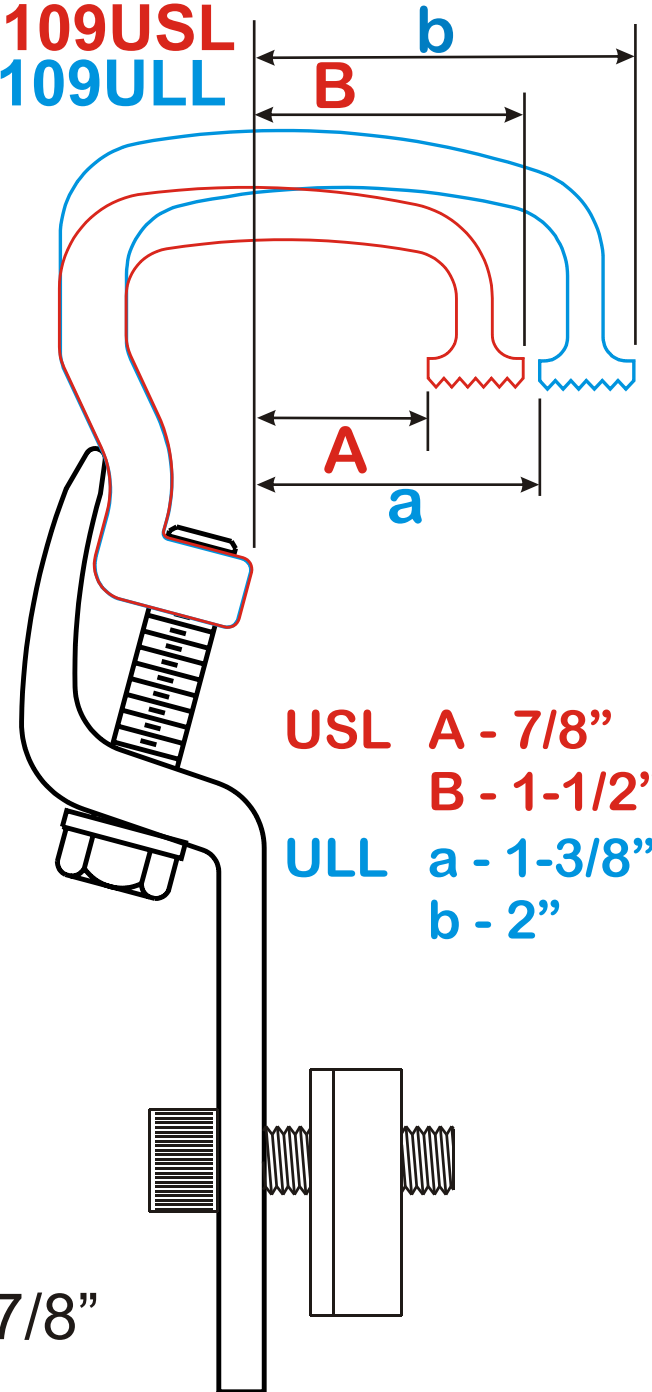

USL A - 7/8"  
B - 1-1/2"  
ULL a - 1-3/8"  
b - 2"

Clamping Range: 7/8"

CLAMPS SHOWN ACTUAL SIZE

AC110US  
AC110UM  
AC110UL

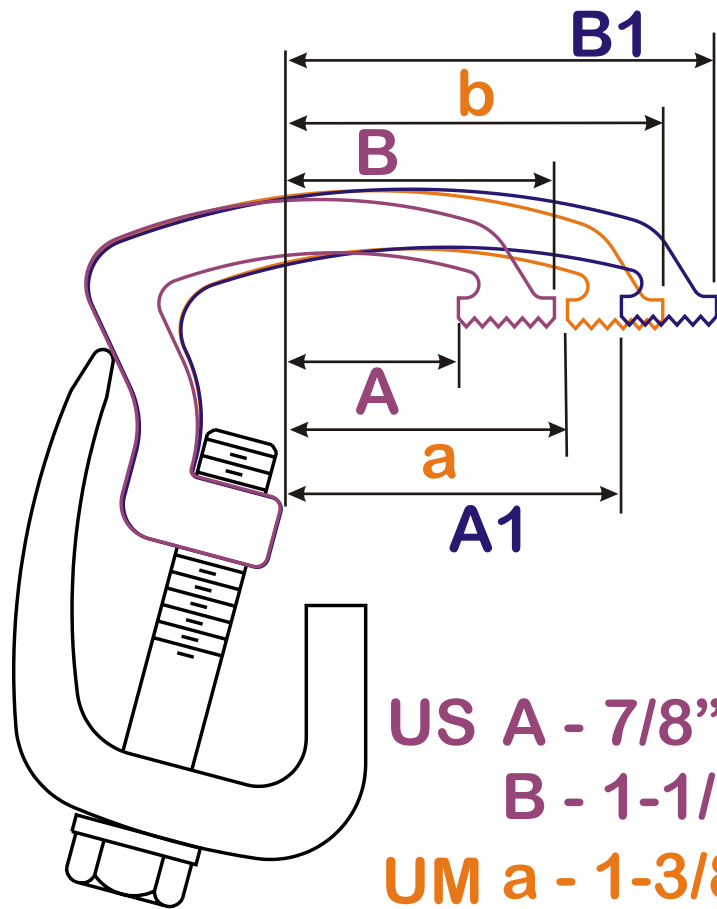

US A - 7/8"  
B - 1-1/2"  
UM a - 1-3/8"  
b - 2"  
UL A1 - 1-5/8"  
B1 - 2-1/8"

**Chevy**  
**StepSide**  
**Clamps**  
**1998**  
**&**  
**Prior**

AC110USL  
AC110ULL

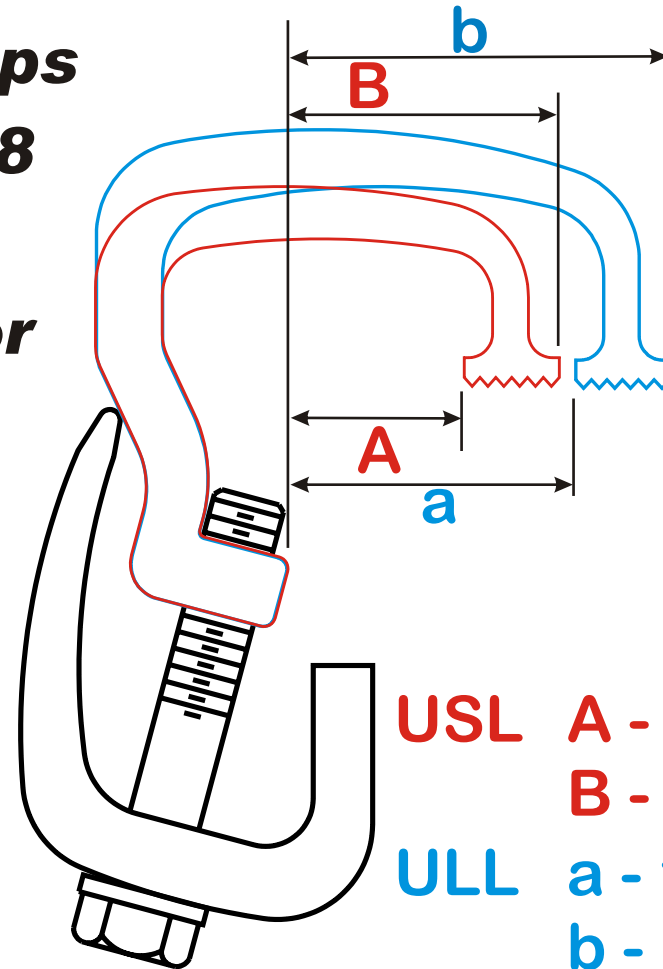

USL A - 7/8"  
B - 1-1/2"  
ULL a - 1-3/8"  
b - 2"

Clamping Range: 7/8"

CLAMPS SHOWN ACTUAL SIZE

AC110US-99  
AC110UM-99  
AC110UL-99

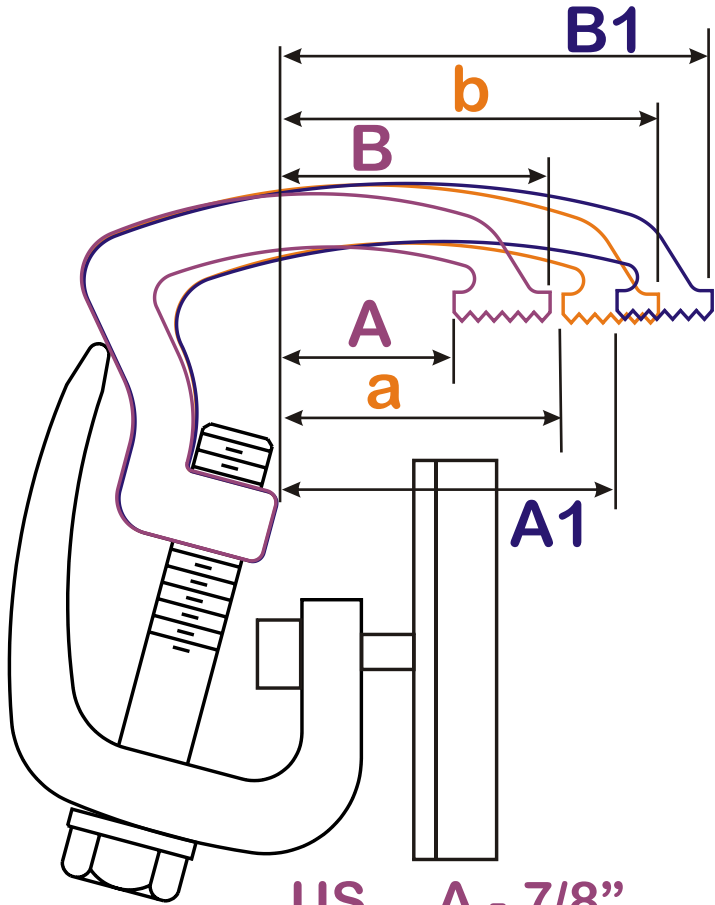

US A - 7/8"  
B - 1-1/2"  
UM a - 1-3/8"  
b - 2"  
UL A1 - 1-5/8"  
B1 - 2-1/8"

**Chevy**  
**StepSide**  
**Clamps**  
**1999**  
**&**  
**Newer**

AC110USL-99  
AC110ULL-99

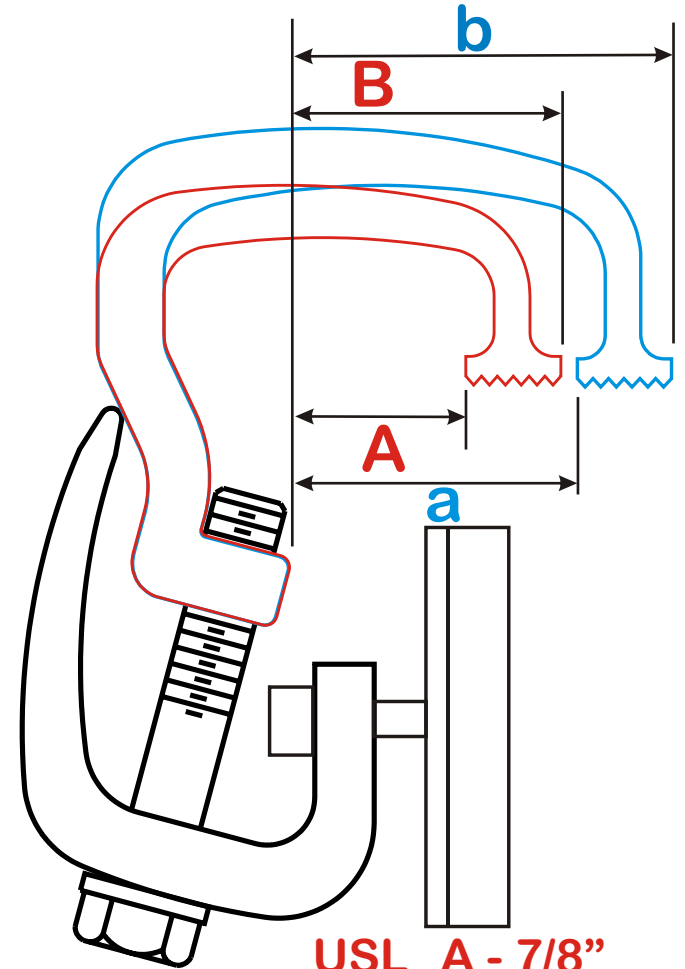

USL A - 7/8"  
B - 1-1/2"  
ULL a - 1-3/8"  
b - 2"

Clamping Range: 7/8"



CLAMPS SHOWN ACTUAL SIZE

AC110US-TC  
AC110UM-TC  
AC110UL-TC

**Toyota  
Tacoma  
Clamps  
2005  
&  
Newer**

AC110USL-TC  
AC110ULL-TC

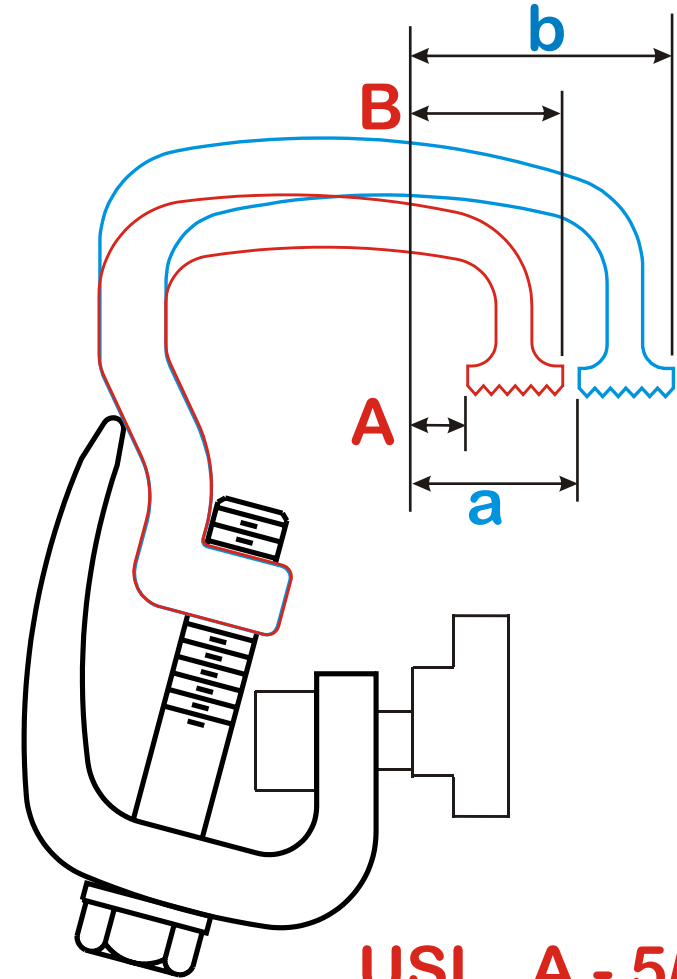
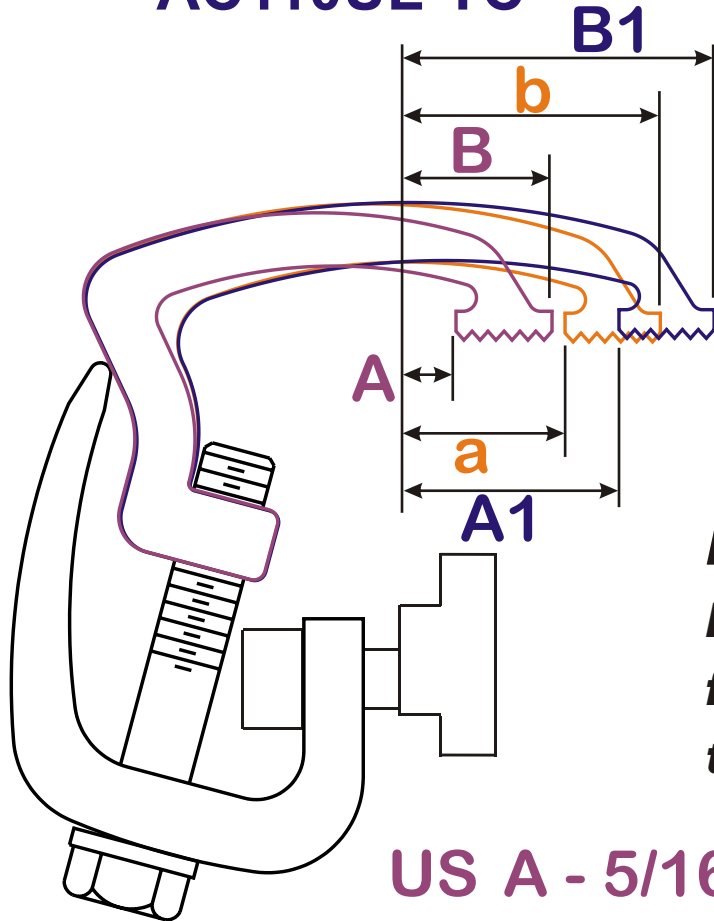

**Note:**  
*Dimensions  
from inside  
truck bed rail.*

US A - 5/16"

B - 15/16"

UM a - 7/8"

b - 1-3/8"

UL A1 - 1-1/8"

B1 - 1-5/8"

Clamping Range: 7/8"

USL A - 5/16"

B - 15/16"

ULL a - 7/8"

b - 1-3/8"

CLAMPS SHOWN ACTUAL SIZE

AC110UM-TU  
AC110UL-TU

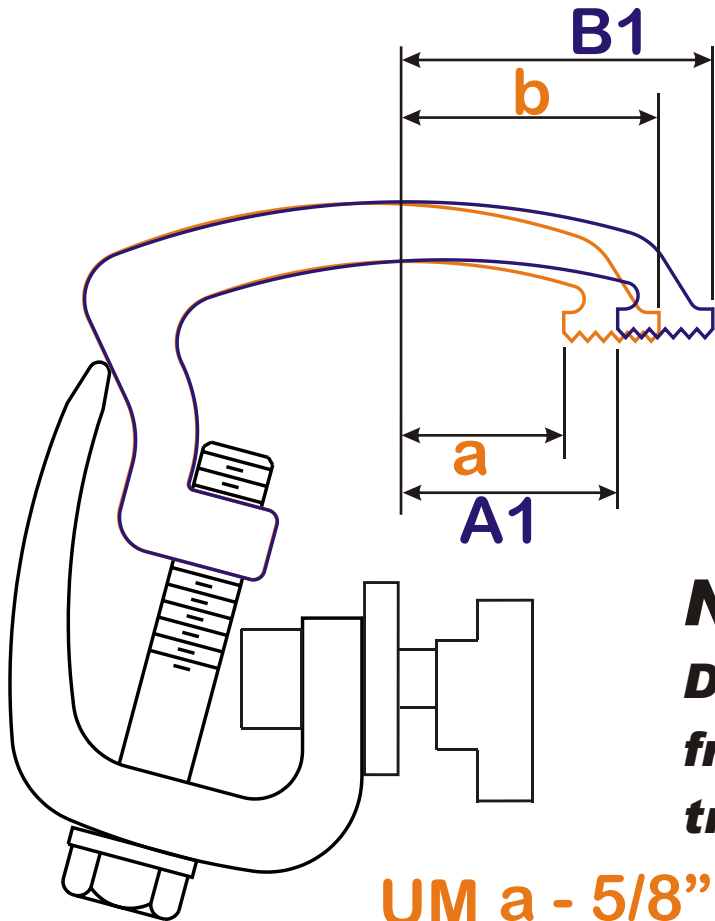

**Toyota  
Tundra  
Clamps  
2007  
&  
Newer**

**Note:**  
*Dimensions  
from inside  
truck bed rail.*

UM a - 5/8"  
b - 1-1/8"  
UL A1 - 7/8"  
B1 - 1-3/8"

AC110ULL-TU

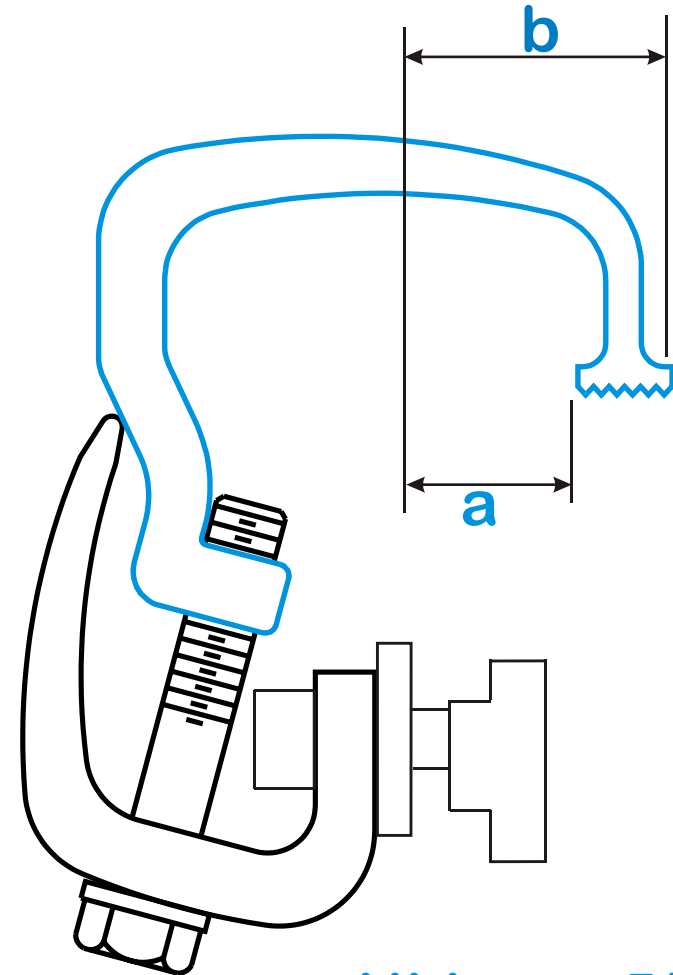

ULL a - 5/8"  
b - 1-1/8"

Clamping Range: 7/8"

CLAMPS SHOWN ACTUAL SIZE

**AC111US**  
**AC111UM**  
**AC111UL**

**Ford**  
**Explorer**  
**Sport Trac**  
**Clamps**

**AC111USL**  
**AC111ULL**

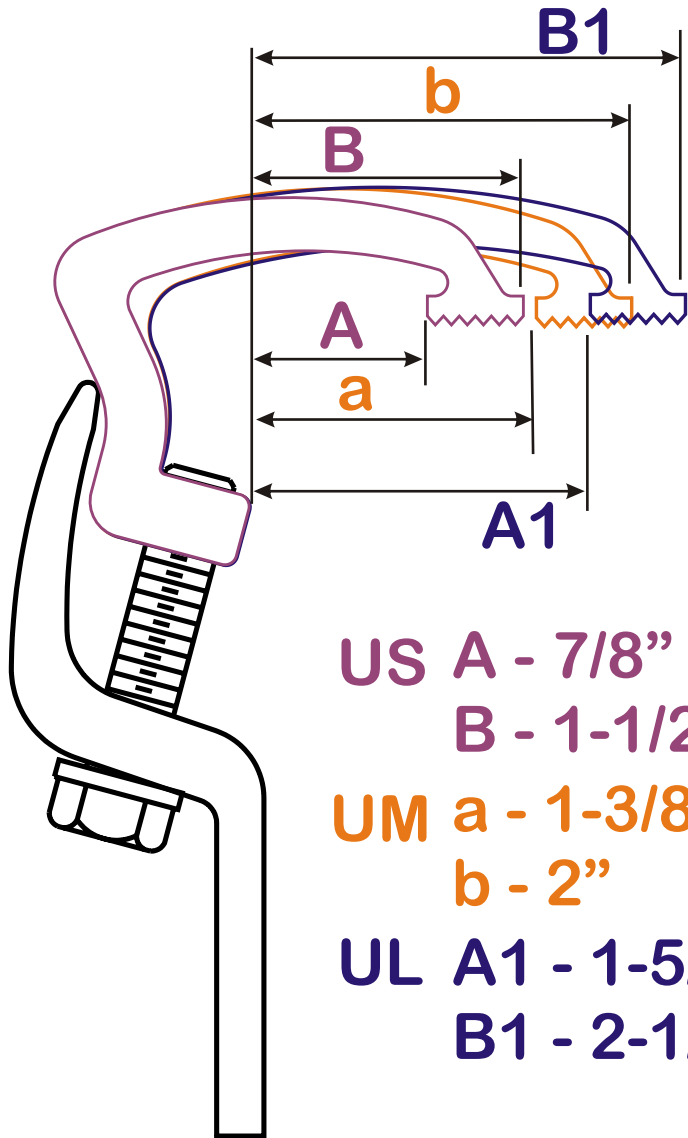

**US** A - 7/8"  
B - 1-1/2"  
**UM** a - 1-3/8"  
b - 2"  
**UL** A1 - 1-5/8"  
B1 - 2-1/8"

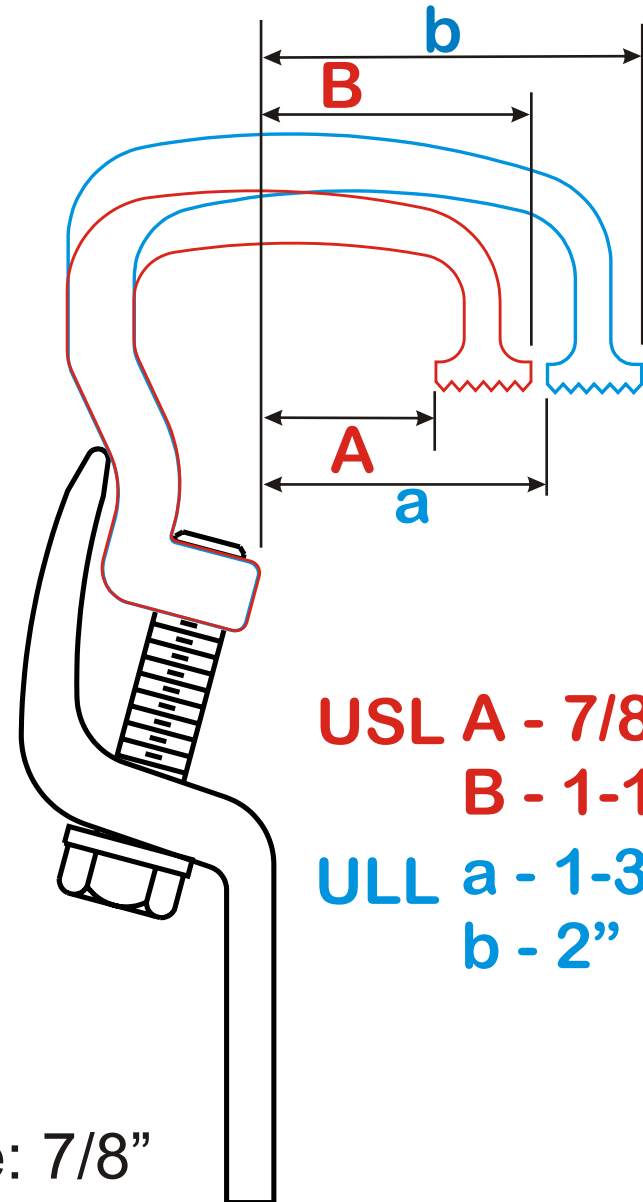

**USL** A - 7/8"  
B - 1-1/2"  
**ULL** a - 1-3/8"  
b - 2"

Clamping Range: 7/8"

CLAMPS SHOWN ACTUAL SIZE

# AC1043

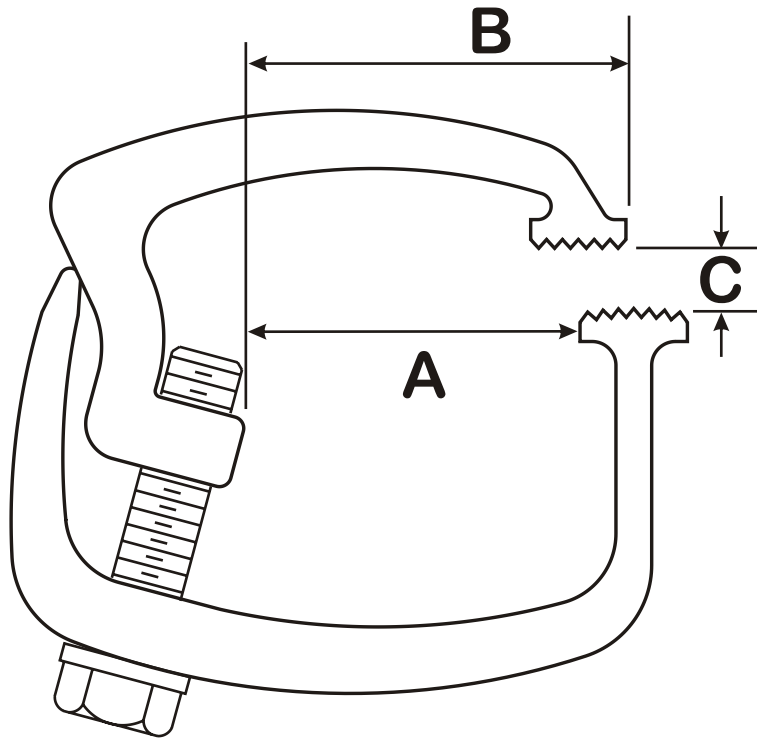

A - 1-3/4"  
B - 2"  
C - 0 to 7/8"

# KH1

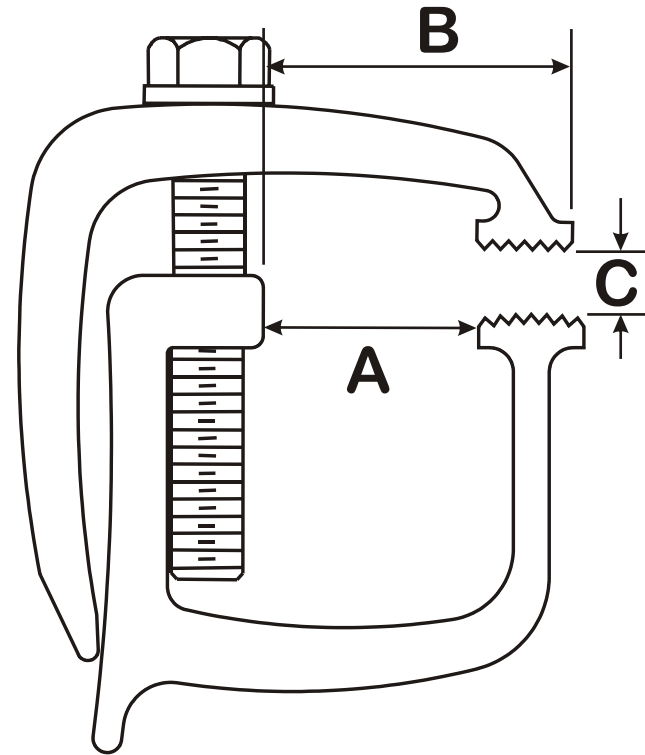

A - 1-1/8"  
B - 1-5/8"  
C - 0 to 1-3/8"

CLAMPS SHOWN ACTUAL SIZE

**SK1**

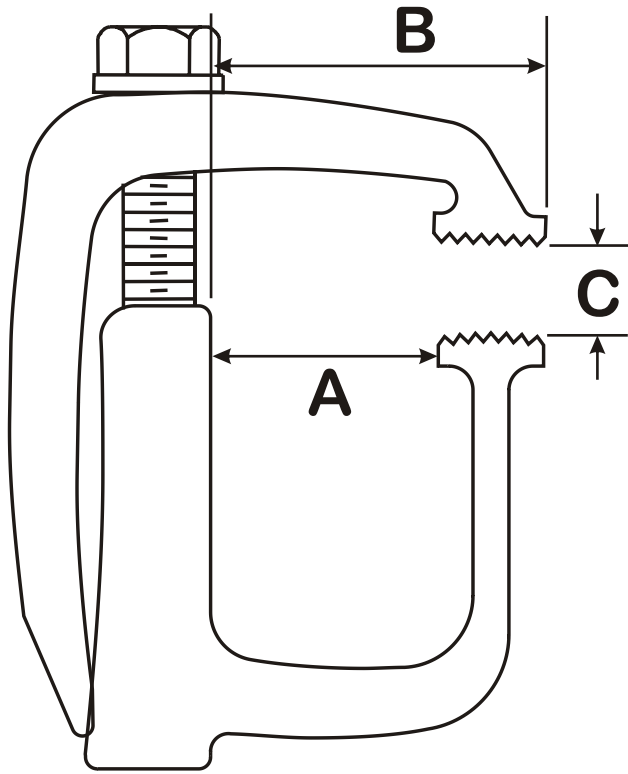

A - 1-3/16"  
B - 1-3/4"  
C - 0 to 1-1/2"

**SK2S**  
**SK2**

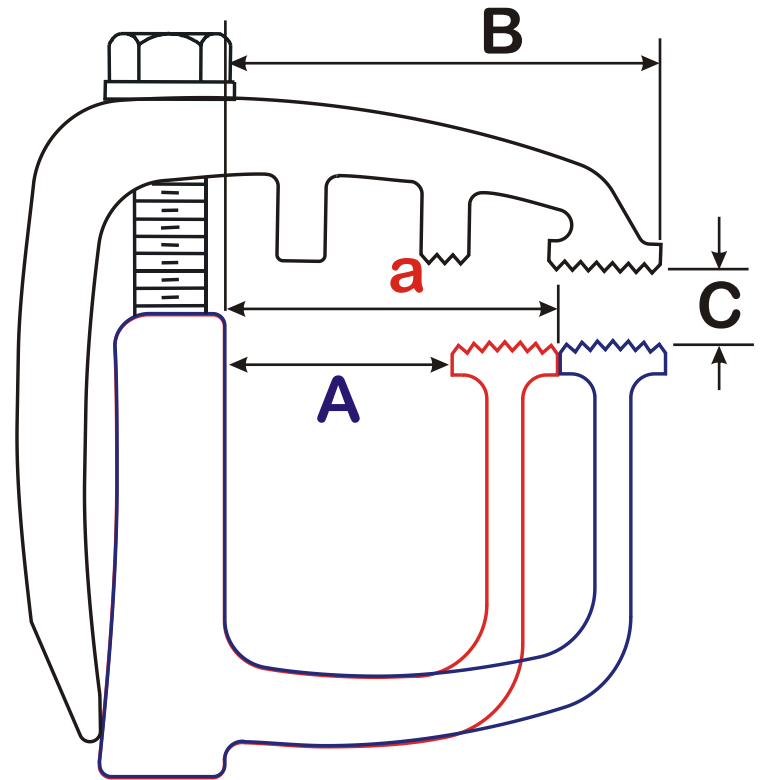

SK2 A - 1-3/4"  
SK2S a - 1-3/16"  
B - 2-5/16"  
C - 0 to 1-1/2"

CLAMPS SHOWN ACTUAL SIZE

**SKC1**  
**SKC2**  
**SKC3**

*Toyota Tacoma  
& Nissan Titan  
Clamps  
2005  
& Newer*

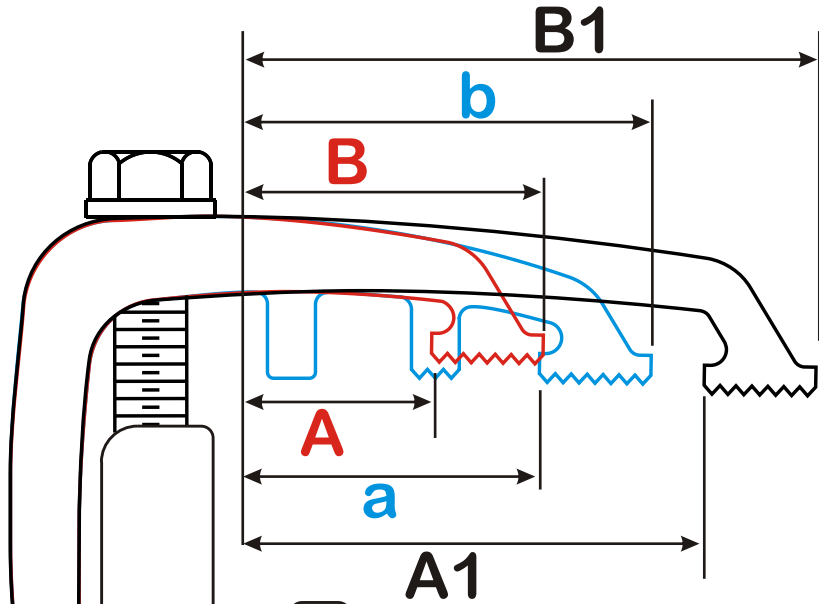

**SKC1** A - 15/16"  
B - 1-1/2"

**SKC2** a - 1-1/2"  
b - 2-1/16"

**SKC3** A1 - 2-5/16"  
B1 - 2-7/8"

**SK10**  
**SK20**  
**SK30**

*Ford  
F Series  
Clamps  
2004  
& Newer*

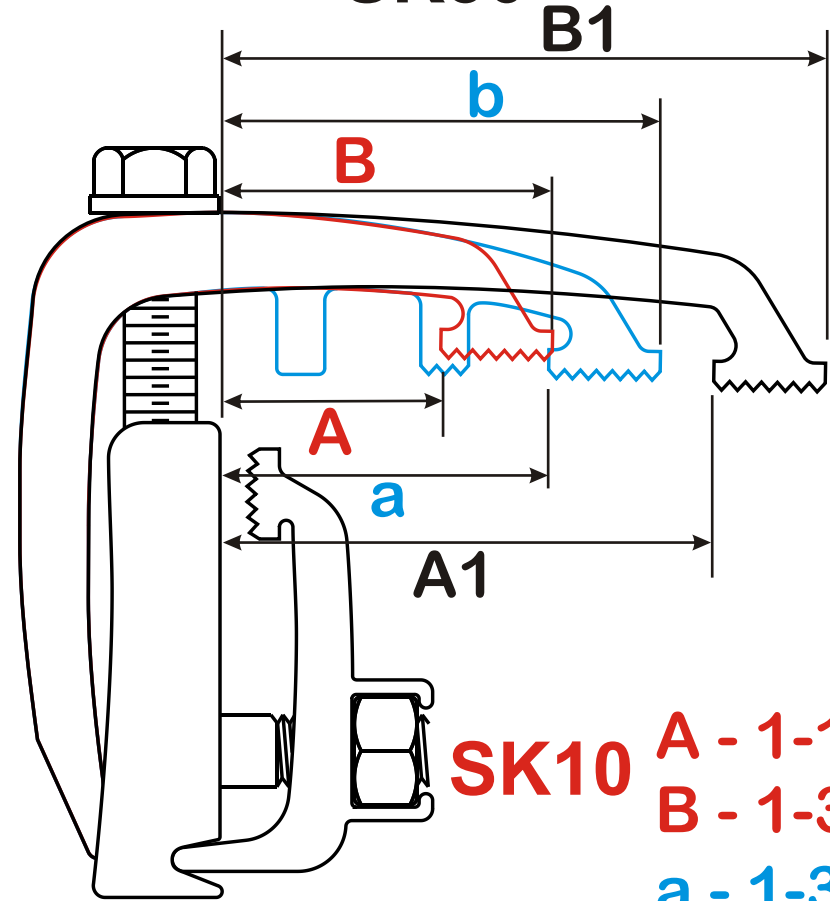

**SK10** A - 1-1/8"  
B - 1-3/4"

**SK20** a - 1-3/4"  
b - 2-5/16"

**SK30** A1 - 2-9/16"  
B1 - 3-3/16"

Clamping  
Range: 1-3/8"